

B-11 Flat Washers

Dayton Superior B-11 Flat Washers are made from flat steel plate and are available in the sizes shown in the accompanying chart. For best results the space spanned by the washer should not exceed the bolt diameter plus 1/4".

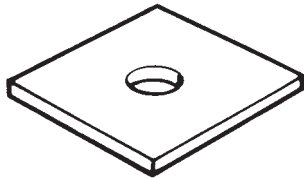

B-11 Flat Washer

To Order:

Specify: (1) quantity, (2) name, (3) bolt diameter.

Example:

1,200 pcs. B-11 Standard, 1/2" bolt.

B-11 Flat Washer Selection Chart			
Bolt Diameter	Type	Safe Working Load (lbs.)	Size
1/2"	Standard	6,750	3" x 4" x 1/4"
1/2"	Heavy	8,750	4" x 5" x 1/4"
3/4"	Standard	14,000	4" x 5" x 3/8"
3/4"	Heavy	14,000	5" x 5" x 3/8"
1"	Standard	18,500	5" x 5" x 1/2"
1"	Heavy	38,000	7" x 7" x 3/4"
1 1/4"	Standard	22,750	5" x 5" x 5/8"
1 1/4"	Heavy	50,750	7" x 7" x 3/4"
1 1/2"	Standard	26,250	5" x 5" x 3/4"
1 1/2"	Heavy	41,500	7" x 7" x 3/4"

SWL provides a factor of safety of approximately 2 to 1.

B-12 Coil Rod

Dayton Superior B-12 Coil Rod is available in 1/2" to



B-12 Coil Rod

1-1/2" diameters in 12' lengths. Field cutting can be accomplished with bolt cutters or carborundum blades.

B-12 threaded rod can be used with Coil Ties in many forming combinations to tie formwork, for adjustable ties, for concrete embedments and/or emergency ties.

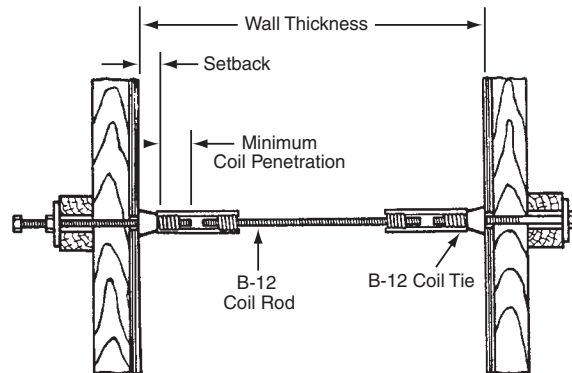

B-12 Coil Rod Selection Chart						
Coil Rod Diameter	Safe Working Loads		Minimum Root Area (sq. in.)	Tensile Stress (psi.)	Yield Stress (psi.)	Minimum Coil Penetration
	Tension (lbs.)	Shear (lbs.)				
1/2"	9,000	6,000	.1385	130,000	110,000	2"
5/8"	12,000	8,000	.2124	113,000	96,000	2-1/4"
3/4"	18,000	12,000	.3079	117,000	100,000	2-1/4"
7/8"	24,000	16,000	.4477	117,000	100,000	2-1/2"
1"	38,000	25,300	.5410	140,000	120,000	2-1/2"
1-1/8"	45,000	30,000	.7163	126,600	105,000	2-1/2"
1-1/4"	56,000	37,500	.9161	123,000	105,000	2-1/2"
1-1/2"	68,000	45,300	1.3892	98,000	85,000	3"

SWL provides a factor of safety of approximately 2 to 1.
Warning: See Page 7 before using B-12 Coil Rod.

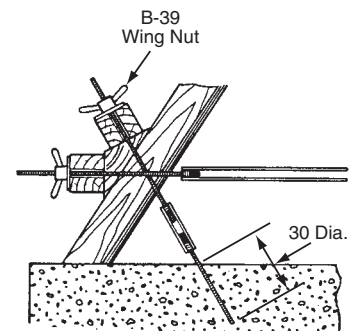

To Order:

Specify: (1) quantity, (2) name, (3) diameter, (4) length.

Example:

500 pcs. B-12 Coil Rod, 1" diameter x 12'-0" long.