



Graham™



Headquarters & Distribution Centers

285 Industrial Drive
Moscow, TN 38057
901-877-3010
Fax: 901-877-1388
www.glasteel.com

2495 N.E. 36th St.
Ft. Worth, TX 76111
817-831-0505
Fax: 817-831-2001

1279 Corporate Center Dr.
Eagan, MN 55121
651-452-0150
Fax: 651-452-0376

Graham / Stabilit Canada, Inc.
64 Maple Ave
Inglewood, ON L7C 1J5
905-838-2944
Fax: 905-838-3386
www.grahamfrp.com



Exceliner® FRP

Wall, Ceiling & Laminated Liner Panels



Graham™

Quality, commitment and innovation

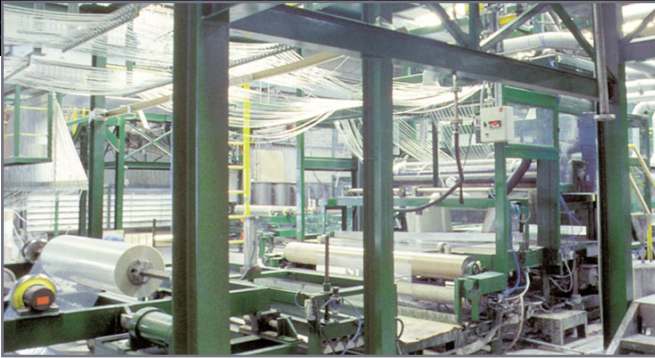

Graham is a division of Stabilit Canada, Inc. Its parent company, Stabilit America, Inc (dba Glasteel and Resolite), is the second largest manufacturer of Fiberglass Reinforced Panels in the North American Market. Our three state-of-the-art manufacturing plants (all ISO 9002 Certified) supply us with the panels that we then provide to our distributors located in most provinces.

Our mission is to offer competitive priced, value added products with the highest quality standards and the best customer service in the industry.



The Best Products, Service, Price & Selection
All Under One Brand

Exceliner® FRP

Wall, Ceiling & Laminated Liner Panels



Exceliner[®] FRP Wall Panels

Resin rich surfaces that are tough, strong and easy to clean.

Applications range from restaurants, supermarkets and car washes to restrooms and storage areas.

Maximum Sanitation Protection

- Meets CFIA and USDA Standards
- Significant cost savings over other materials

Excellent Quality

- Years of dependable performance
- Blend of special high strength polyester resin combined with fiberglass reinforcement
- Superior durability

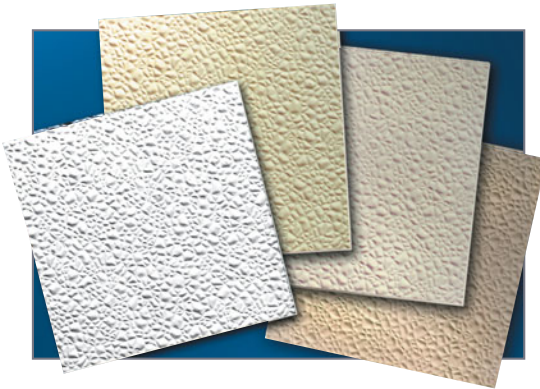

Moisture Resistant

- Non-porous, resin rich surface does not allow moisture penetration
- Does not support mold or mildew

Highly Impact Resistant

- Extremely high strength to weight ratio
- Tough surface that resists shattering, scratches, abrasions and dents

Outstanding Cleanability

- Cleans with regular detergents and water
- Minimum maintenance and never needs painting or surface finishing





Improved Chemical Resistance

- Stain resistant
- Rust proof - will not corrode
- Highly resistant to most mild acids, alkalis and most common solvents

Superior Flexibility

- Panels are flexible enough to lay flat, allowing a better fit into areas with close tolerance seams

Custom Designed Liner Panels

- Available in 5 different standard panel thicknesses (see side chart)
- Custom colour matching available with minimum quantity requirements
- Width up to 102" and lengths up to 500' coil are available with minimum quantity requirements

Wall Panel Specifications

Exceliner FRP is available in the following sizes:

Series	Nominal Thickness
1600	.125"
1200	.090"
180	.060"
160	.045"
150	.035"

Width Standard 4 Feet

Length 8, 9, 10 and 12 Feet

Thickness Standard 0.090"



Low Cost Installation

- Easy to handle and install in any type of construction, and over any type of existing wall surface
- No special tools needed
- More economical than stainless steel or ceramic tile



Approvals & Certifications

- **ISO 9002:** All Stabilit plants are ISO 9002 Certified
- **Meets USDA/FSIS requirements**
- **Canadian Food Inspection Agency (CFIA) accepted**
- **ICC:** Report # ER-2364
- **ASTM:** All Exceliner FRP liner panels are manufactured according to industry standard ASTM D-3841-2001
- **FM Approvals:** All Exceliner FRP liner panels are tested and listed by FM Approvals
- **ULC-S102 E84**



Typical Physical Properties for .090" Contractor Grade

Property	Test Method	Unit	Class C General Purpose Result	Class A Fire Retardant Result
Flexural Strength	ASTM D-790	PSI	17,000	10,000
Flexural Modulus	ASTM D-790	PSI	6.0×10^5	3.1×10^5
Tensile Strength	ASTM D-638	PSI	8,000	7,000
Tensile Modulus	ASTM D-638	PSI	9.43×10^5	3.1×10^5
% Elongation	ASTM D-638	%	1.20	1.80
Water Absorption 21°C @ 72 hrs.	ASTM D-570	%	0.17	0.72
Izod Impact Strength	ASTM D-256	ft.-lbs./in.	7.0	7.16
Coef. of Linear Thermal Expansion	ASTM D-696	in./in./°F	2.22×10^{-5}	2.39×10^{-5}
Barcol Hardness	ASTM D-2583	Avg.	30	35
Specific Gravity	ASTM D-792	N/A	1.6138	1.5743
Abrasion Resistance	TABER	% WT Loss	0.293	0.391
Flash Ignition Temp.	ASTM 1929	°C	430	400
Self Ignition Temp.	ASTM 1929	°C	450	430
Flame Spread	ASTM E-84	N/A	≤150	≤25
Smoke Generation	ASTM E-84	N/A	<450	<450

Storage Recommendations

- Store panels indoors in a cool, dry, well-ventilated area
- Panels should be stacked on skids not more than 5 skids high
- Do not allow moisture to collect on or in-between panels



Colour Selections



Bright White

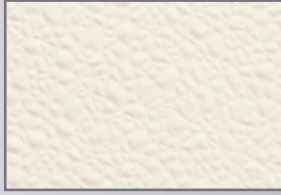

Almond



Beige



Ivory



Silver

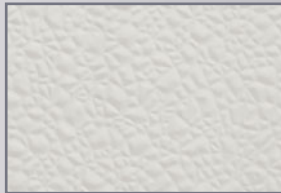

Light Gray



Black

Two Surface Finishes

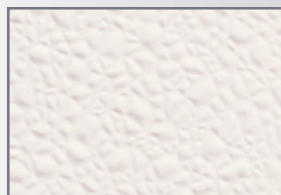

Traditional pebbled finish

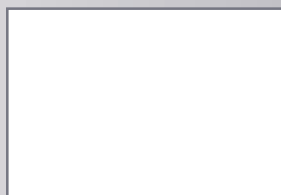

Premium Gel Coat smooth finish

Safety:

- Use eye protection.
- Wear filter mask to cover nose and mouth, especially when cutting.
- Use manufacturer's recommended sealants and adhesives.

Tools Needed:

- Power or hand saw (fine tooth or carbide blade)
- Power or hand drill (carbide tip recommended)
- Carpenter's square
- Hammer, tape measure and level
- Adhesive and notched trowel
- Silicone sealant and caulking gun
- Vinyl moldings and 3/4" nylon fasteners

Preparation:

- It is important to store Exceliner FRP flat, on a clean, dry surface for 24 hours before installation. It is preferable to store them inside the actual area of installation or, at least, under similar climate conditions.
- Walls must be clean and free of all substances.
- Level any high or low spots on walls. Concrete block walls may require a leveling coat of plaster or other similar material.



Installation of FRP Laminated Panels, in any application, should be approved by local building code officials before panels are ordered. Graham cannot ensure local code compliance in any or all situations. **NOTICE:** Panels and components made of fiberglass (FRP), wood, vinyl or foam may be combustible. **DISCLAIMER and LIMITATION of Liability:** The information contained in this literature is presented in good faith, and is believed to be accurate and reliable at time of publication. No representation, guarantee or warranty is made as to the completeness, reliability or accuracy of this information. This also includes **NO IMPLIED WARRANTY OR MERCHANTABILITY OR FUNCTIONAL USE FOR SPECIFIC APPLICATION.**

Cutting Exceliner FRP for Floor to Ceiling Heights of 8 Feet or Less:

- Subtract 1/2" from height measurement to allow for expansion.
- Allow for 1/8" expansion gap around pipes and other projections.

Drilling Fastener Holes:

- Pre-drill fastener holes before applying adhesive.
- Fastener holes should be slightly oversize to allow for normal expansion and contraction.
- Drill holes no further than 8" apart and 1" from outside edge, 16" apart on intermediate and on 16" centers.

Installation reminders:

1. Follow safety and fire guidelines during installation and use of panels.
2. First panel installed should be set true with plumb line.
3. Wall must be clean and flat.
4. Use mouldings, silicone, nylon rivets and adhesive for best installation.
5. Apply adhesive.
6. Install panels and mouldings.
7. Seal edges and mouldings.
8. Remove excess silicone.
9. Clean panels after installation with light detergent.



Accessories



Inside Corner



End Cap



Divider Bar



Outside Corner



Outside Corner Angle



Nylon Rivets



FRP Adhesive

Applying Adhesive

- For best installation, combine adhesive and nylon fasteners.
- Exceliner FRP should never be installed on uneven walls using only adhesive.
- Apply adhesive to panel, not wall, using 100% coverage with notched trowel.

Actual requirements may vary. Call Graham for complete installation instructions.



Exceliner® FRP Ceiling Panels

Applications

- Food processing areas
- Restaurants
- Bathrooms
- Storage rooms
- Schools
- Hospitals
- Many other applications where sanitation is required

Characteristics

- Moisture resistant - does not support mold or mildew
- Rust proof - will not corrode
- Stain resistant
- High strength-to-weight ratio
- Easily removable for cleaning

Easy to Install

- Cut to size for easy installation
- Lightweight and easy to handle

Minimal Deflection

- Panel formulation makes for a strong, rigid ceiling panel



Ceiling Panel Specifications

Sizes 23 3/4" x 23 3/4"
23 3/4" x 47 3/4"

Thickness 0.100"

Finishes Textured or Smooth

Colour Standard Colours

Sag Tolerance < .25"

Fire Rating

- Class C: General Purpose
- Class A: Fire Retardant



Exceliner® FRP Laminated Panels

Why use Laminated FRP panels?

- Ease of installation
- Reduced labor costs
- Durable
- Sanitary
- Easily Maintained

Ideal for:

- Agricultural buildings
- Kitchens
- Fast food restaurants
- Restrooms
- Storage areas
- Laboratories
- Food processing plants
- Health care facilities
- Convenience stores
- Kennels and veterinary clinics
- Walk-in coolers and freezers

FRP Panels are laminated to:

- Plywood
- OSB



Mouldings

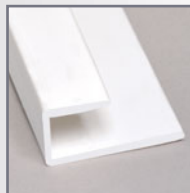

3/8" Cap
(.460 opening)



3/8" Divider
(.460 opening)



3/8" ISC/Cove
(.460 opening)



3/8" OSC
(.460 opening)



1-1/2"
OSC Angle



1-1/2"
ISC Angle



2-Piece
Divider

Laminated Panel Specifications

Sizes 4' x 8' and 4' x 10'

Substrate Thickness 3/8" standard

Colour Bright White

For other substrates, colors or sizes, please contact Graham.





Exceliner® FRP Foundation Liner

Exceliner® pays for itself quickly with increased energy efficiency and lower power costs.

Features



- UV Resistant
- .060" thickness
- Stain, odor and moisture resistant
- Insect and pest resistant
- Shatter resistant
- Energy efficient
- Attractive gray pebbled finish adds value to your property
- Protects basements and crawlspaces from flooding
- Easy to install on both existing buildings and new construction
- Can be installed directly to solid walls or over insulation
- Stays strong and sturdy in any season
- 10 year Limited Warranty

Sizes

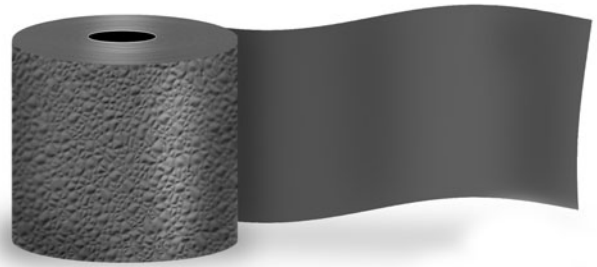
- Standard 50' lengths
- 1', 2' and 4' widths.

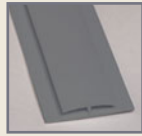
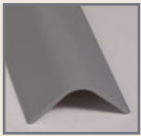

Recommended Accessories

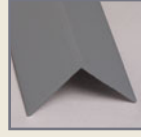
Division Bar		Inside Corner Angle 1 1/4" x 1 1/4"	
Nylon Rivets 1/4" Plastic Pins Available up to 2"		Outside Corner Angle 1 1/4" x 1 1/4"	

*Savings from insulated foundations vary with fuel prices, heating equipment, performance, and climate.

Exceliner can be installed directly to solid walls or over insulation. As an extra barrier of protection against moisture and insects, Exceliner also traps in the energy used to heat and cool your home.

According to the DOE published literature, heat loss from an un-insulated, conditioned basement may represent up to 50% of a home's total heat loss in a tightly sealed, well-insulated home.

And since concrete offers little resistance to heat flow/loss in a well insulated home, it is recommended by the DOE to insulate the foundation of a home. Insulating the foundation of a home can reduce the horizontal heat flow through the wall into the earth and the vertical heat loss through the concrete wall and into the air above the grade line. Exceliner Foundation Liner will protect the insulation used on your foundation.

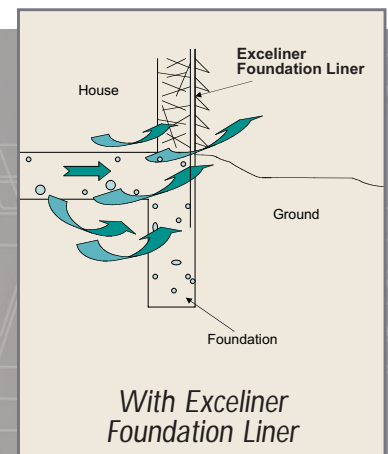
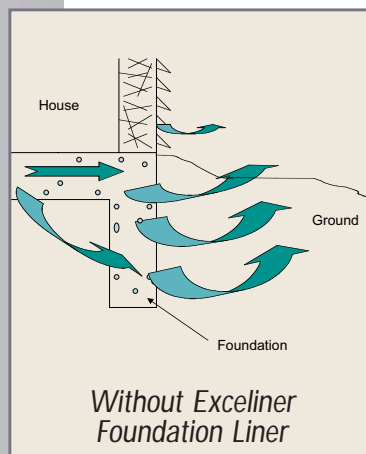

The Best Products, Service, Price & Selection All Under One Brand

Independent Laboratory Test Results

REASON FOR ANALYSIS: Evaluation of the **White Exceliner FRP Panel** from the viewpoint of overall stain resistance properties as well as resistance to chemical cleaners and high intensity UV light.

EXECUTIVE SUMMARY: The **White Exceliner FRP Panel** demonstrates good overall stain resistance properties both before and after surface abrasion tests. In addition the **White Exceliner FRP Panel** demonstrates good resistance to high intensity UV light and general household cleaning chemicals such as bleach, ammonia, alcohol and acetone with no material degradation noted after exposure tests.

EVALUATION OF FINDINGS:

Stain Resistance Properties: The **White Exceliner FRP Panel** demonstrates good overall stain resistance properties on the original surface with all stains being removed after cleaning tests. The abraded surface demonstrates generally good stain resistance with only the ink stain remaining visible after cleaning tests. The stain resistance test consists of applying generous amounts of a variety of stains, including red fruit drink, ketchup, mustard and barbecue sauce as well as some very aggressive stains such as blue ink and permanent marker. These stains were applied to the original as received surface and to a surface which was abraded with sandpaper to remove any surface coatings. The stains were then allowed to set for a period of 48 hours. The stained areas were then cleaned with a variety of cleaning chemicals to determine overall cleanability. The ketchup, fruit drink and barbecue sauce were all easily removed with a typical household cleaner on both the abraded and original surfaces. The mustard and permanent marker did require use of a stronger chemical such as alcohol and acetone to fully remove the stains. It should be noted the blue ink stain was not completely removed on the abraded test surface when using all the listed cleaning chemicals.

UV Resistance: The **White Exceliner FRP Panel** exhibits no discolouration or other surface degradation after 60-hours of exposure to high intensity UV light.

Chemical Resistance: The **White Exceliner FRP Panel** surface showed no evidence of material degradation after exposure to household cleaner, ammonia cleaner, bleach (1% solution), alcohol (70% isopropyl) and acetone.

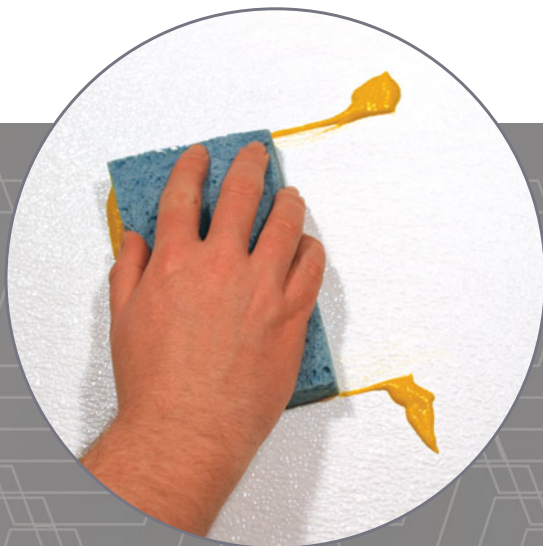

Before Stain Cleaning Test

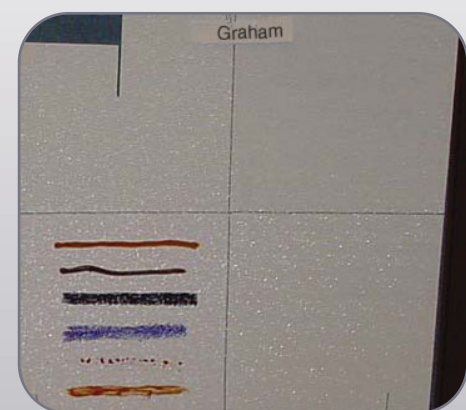

After Stain Cleaning Test