

B-27 and D-6 Nut Washer

Dayton Superior B-27 and D-6 Nut Washers combine the advantages of a washer and nut into a one-piece ductile iron unit. The nut washer is equipped with nailing holes to secure them to the formwork and are designed to spread the forming loads over the wood forming members. The B-27 Nut Washer has coil thread in the sizes displayed in the chart and can be used with all appropriate coil threaded devices. The D-6 Nut Washer is equipped with Acme thread and is normally used with the D-2 She-Bolt, seen on Page 74.

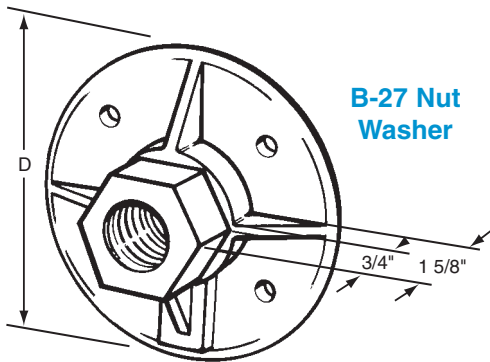

B-27 and D-6 Nut Washer Selection Chart				
Type	Thread		Safe Working Load Tension (lbs.)	D
	Diameter	Type		
B-27	1/2"	Coil	4,500	4"
B-27	3/4"	Coil	9,000	4"
B-27	7/8"	Coil	12,000	5"
B-27	1"	Coil	18,000	5"
D-6	3/4"	Acme	9,000	4"

SWL provides a factor of safety of approximately 2 to 1.

To Order:

Specify: (1) quantity, (2) name, (3) diameter, (4) thread type.

Example:

100 pcs., B-27 Nut Washer, 1/2" coil thread.

B-29 Loose Plastic Cone

Dayton Superior B-29 Loose Plastic Cones are used with B-1 and B-2 Coil Ties. They are placed on the coil bolts after the coil bolts have been inserted through the form face but prior to threading the bolt into the coil tie. The large end of the cone provides sufficient bearing surface to prevent crushing of the plywood around the bolt hole. B-29 plastic cones are removed from the concrete with a B-15 Cone Removal Wrench and can be reused.

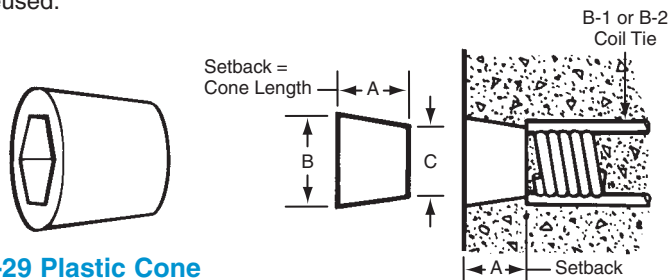

B-29 Plastic Cone

To Order:

Specify: (1) quantity, (2) name, (3) bolt diameter, (4) setback.

Example:

2,000 pcs. B-29 Loose Plastic Cone, 1/2", 2" setback.

B-29 Loose Cone Selection Chart			
Bolt Diameter	Setback (Cone Length) A	Bolt Diameter	
		B	C
1/2"	1"	1-1/4"	1"
1/2"	1-1/2"	1-1/4"	1"
1/2"	2"	1-1/4"	1"
3/4"	1"	1-5/8"	1-7/16"
3/4"	1-1/2"	1-5/8"	1-7/16"
3/4"	2"	1-5/8"	1-7/16"
1"	1"	-	-
1"	2"	-	-
1"	2-1/2"	2-1/8"	1-3/4"
1-1/4"	2"	-	-
1-1/4"	2-1/2"	2-3/8"	2-1/8"

SWL provides a factor of safety of approximately 2 to 1.